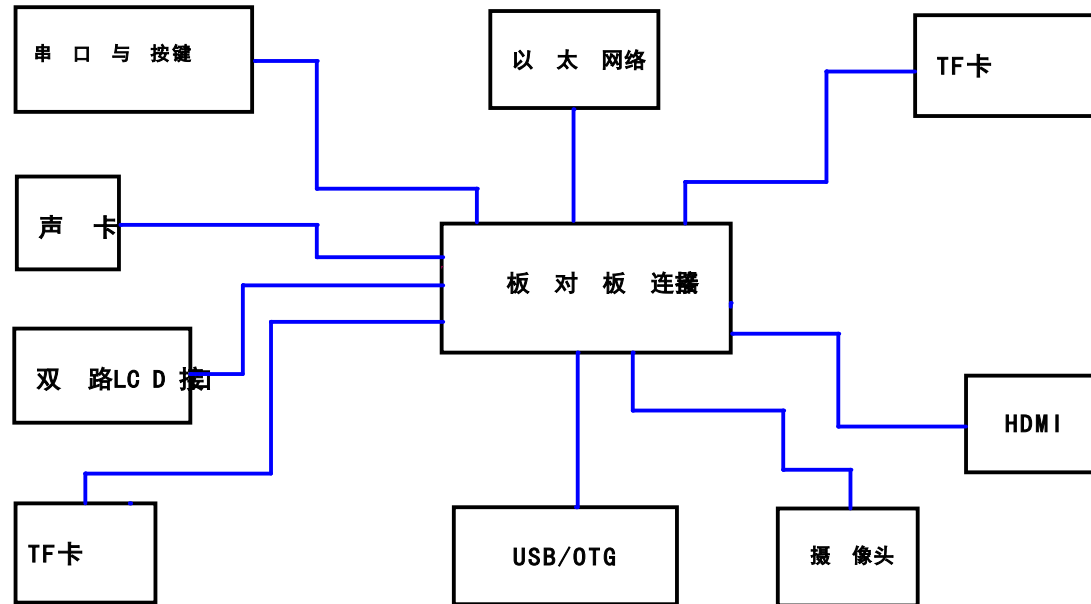
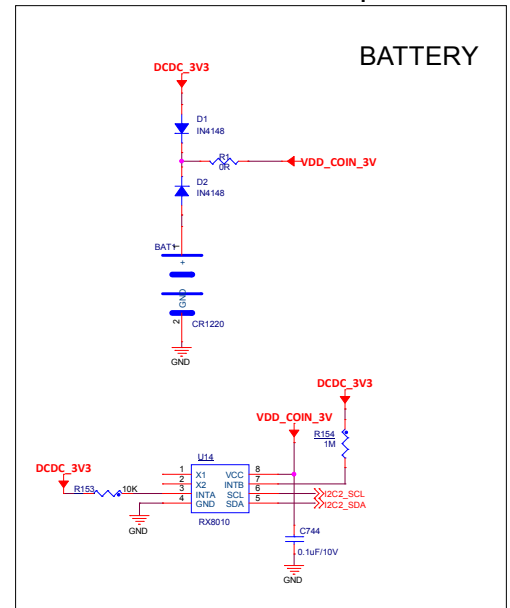

Table of Contents	Part Reference	Details of Revision





Mounting holes Boards



CAN

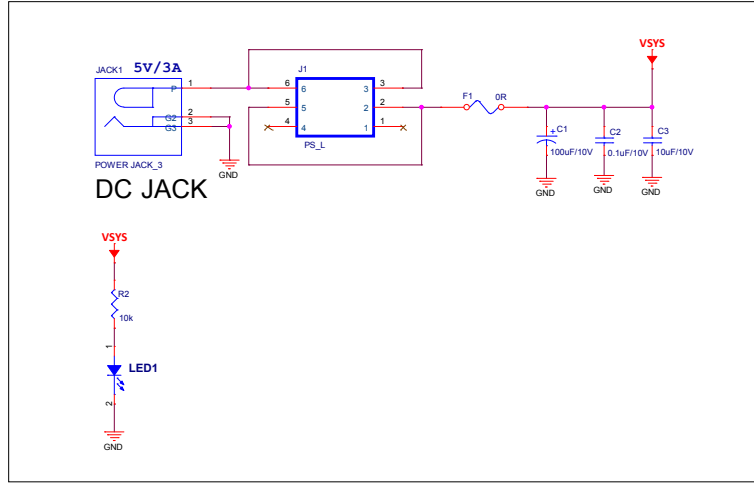
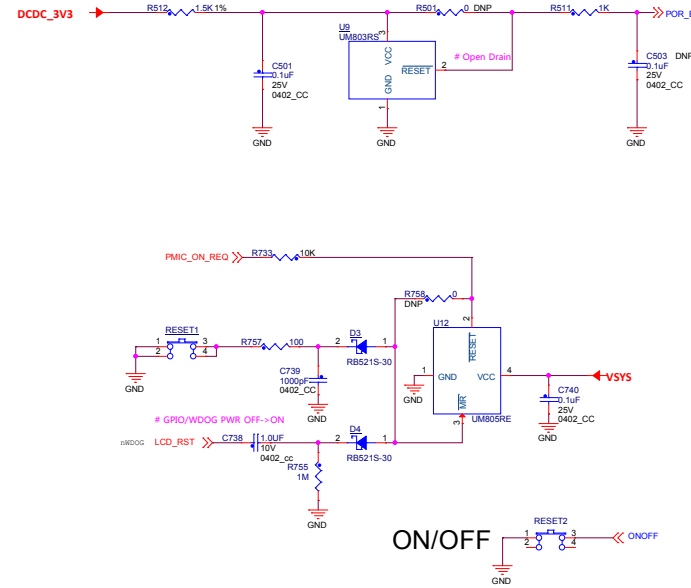
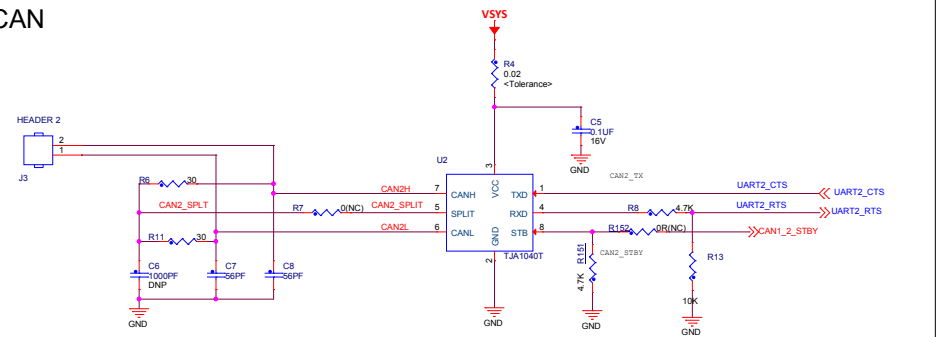

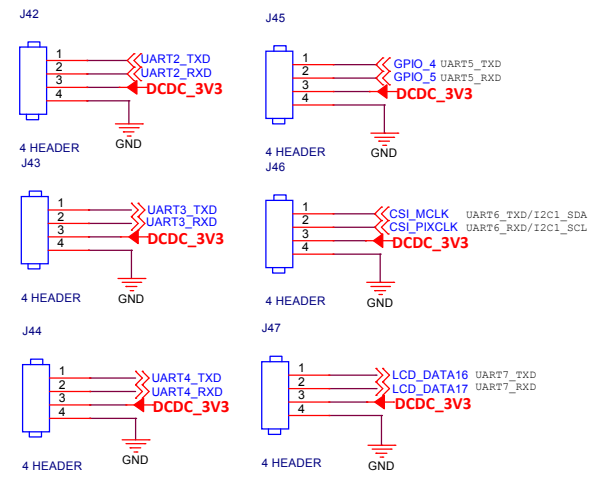
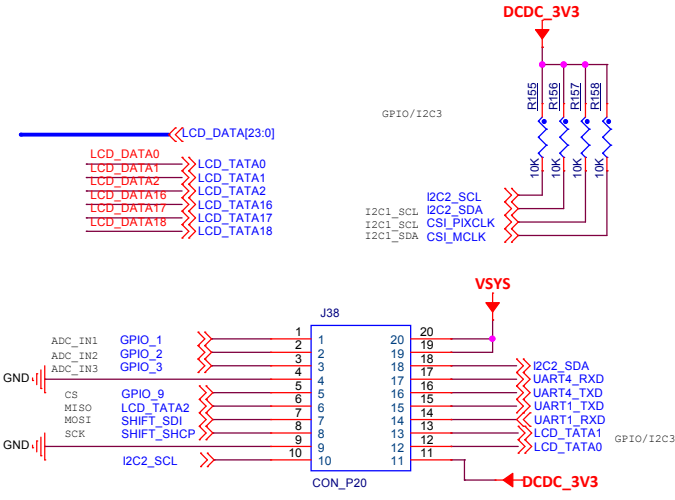
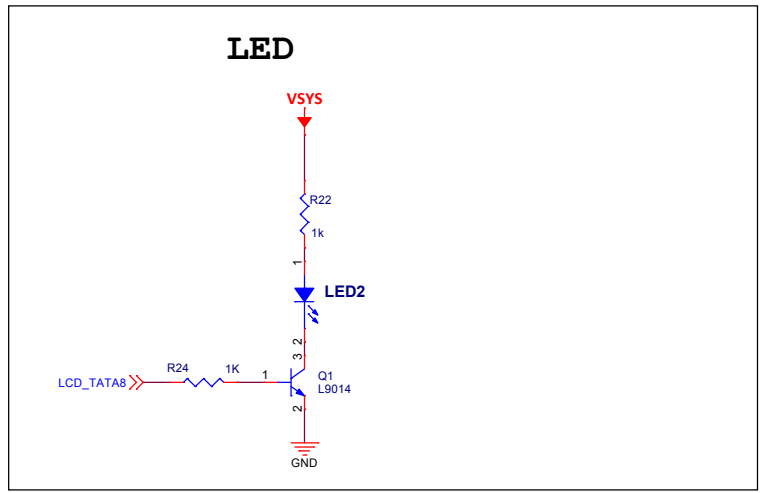
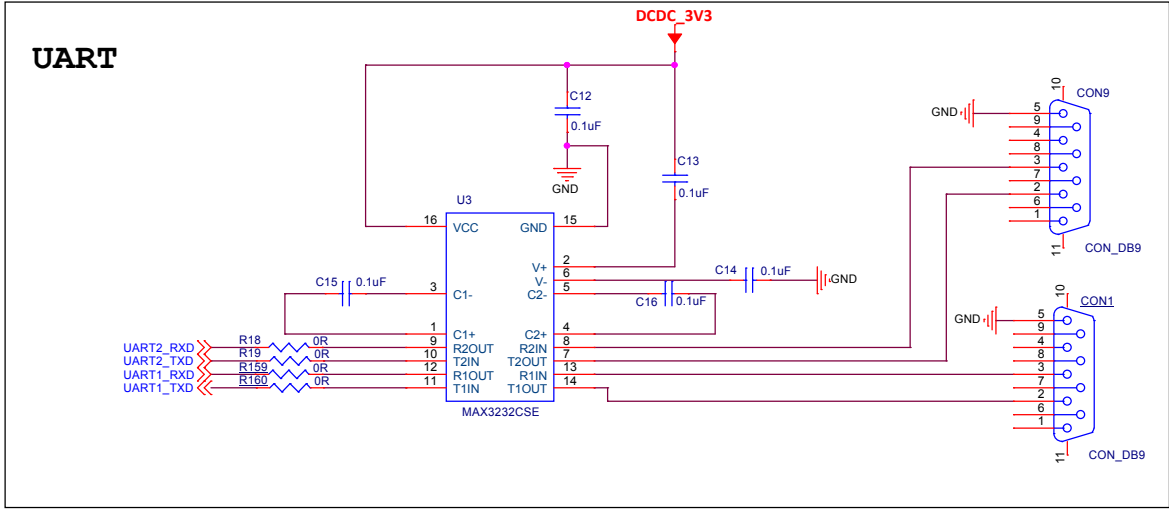

100M ETHERNET RMII PHY x1

PHY PWR

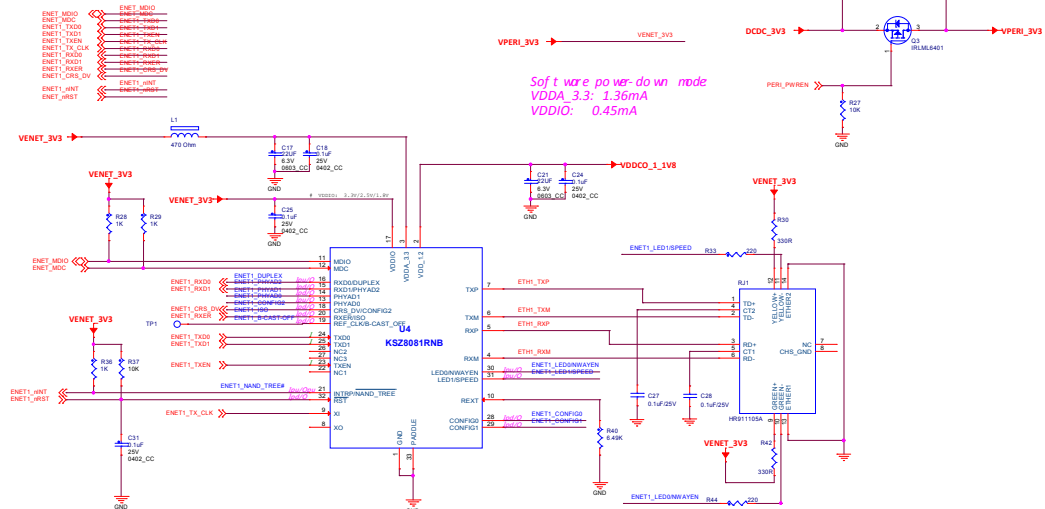

100M ETHERNET RMII PHY x2

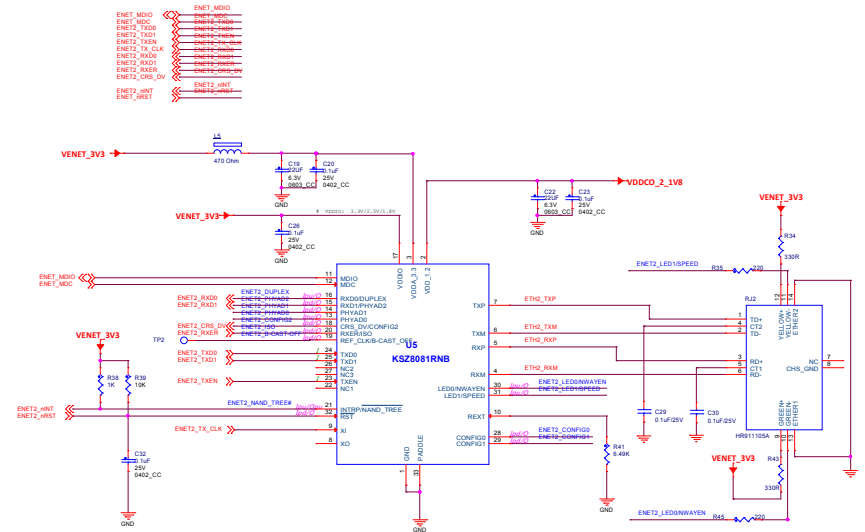

RMII CFG

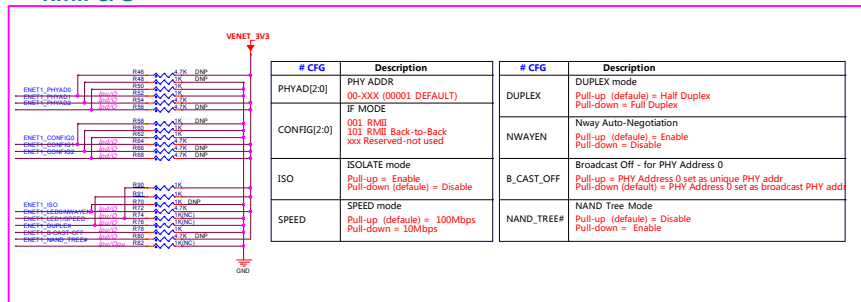

RMII CFG

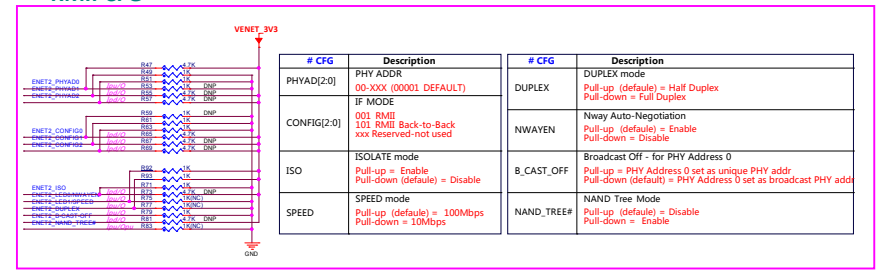

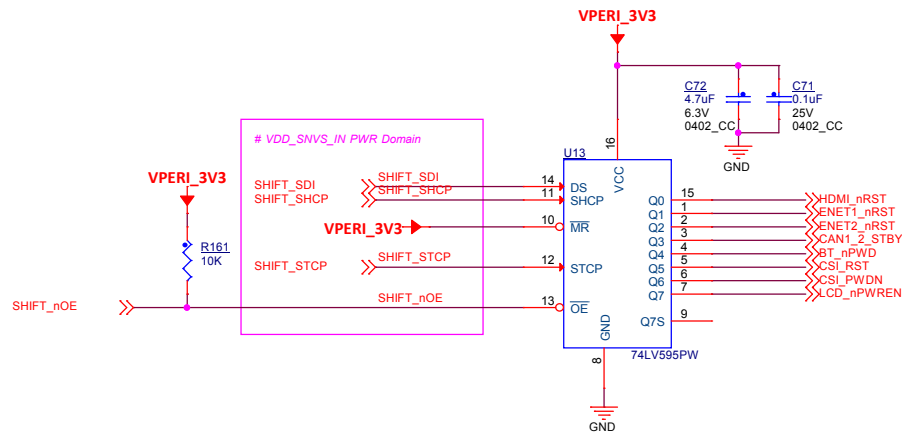
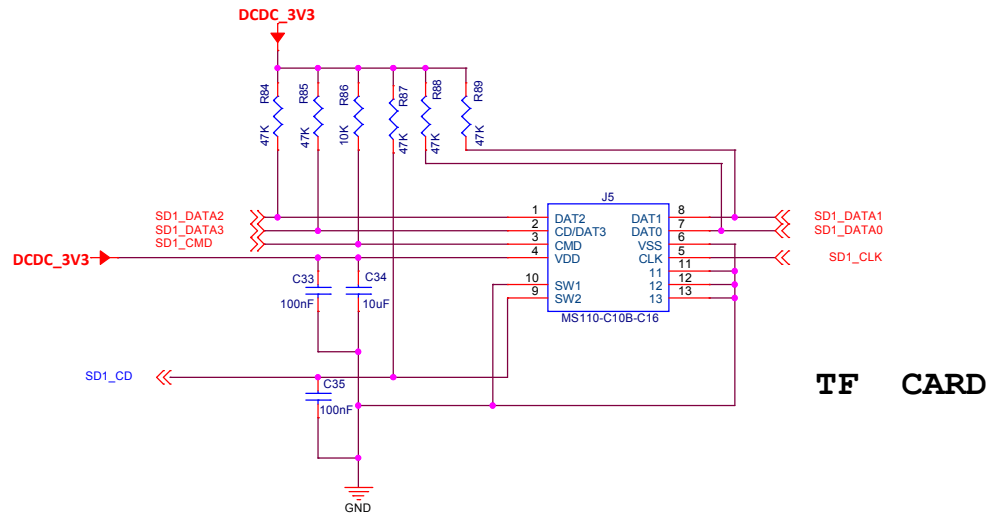

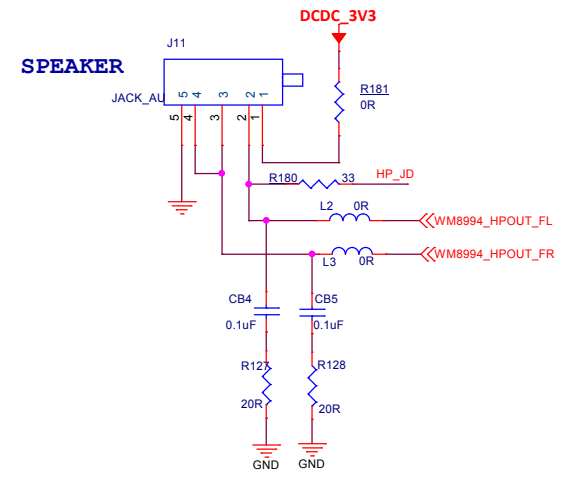
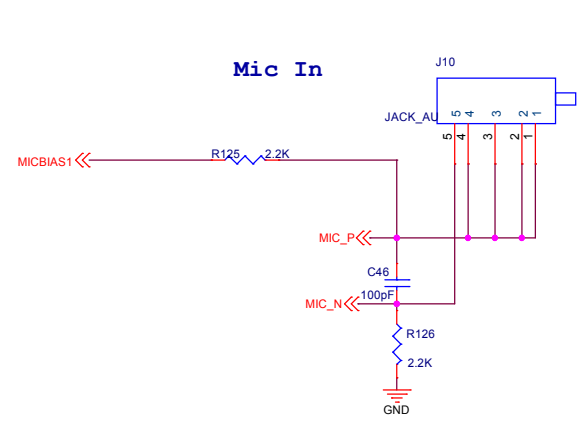
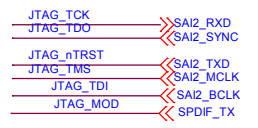
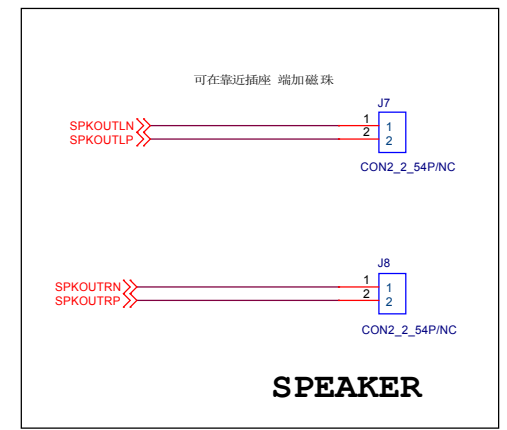
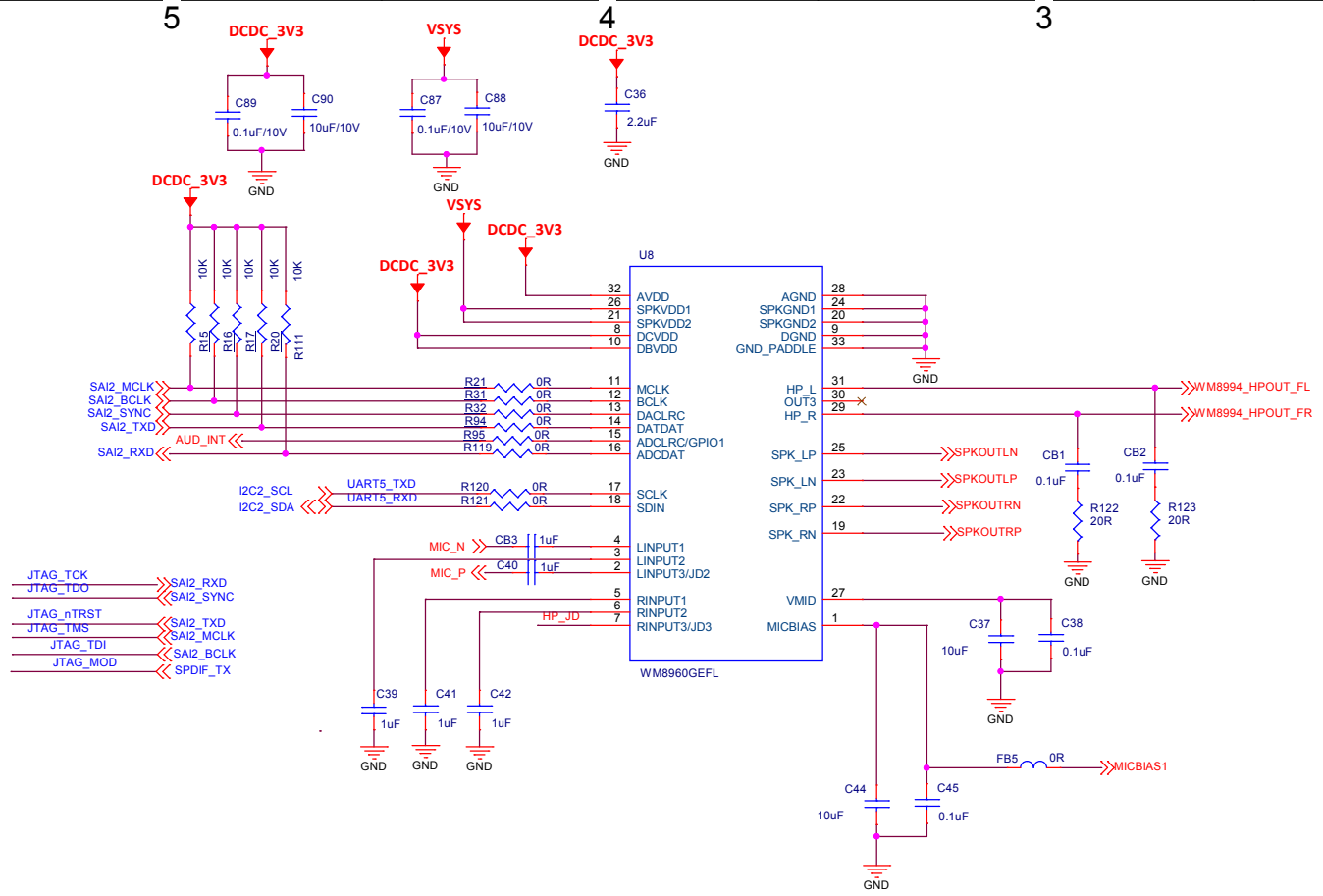

RGB TO LVDS

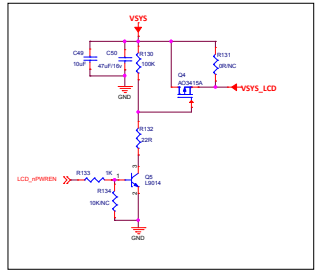
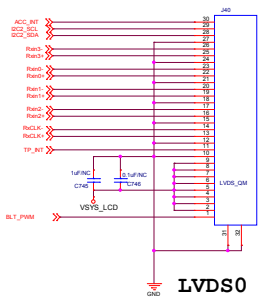
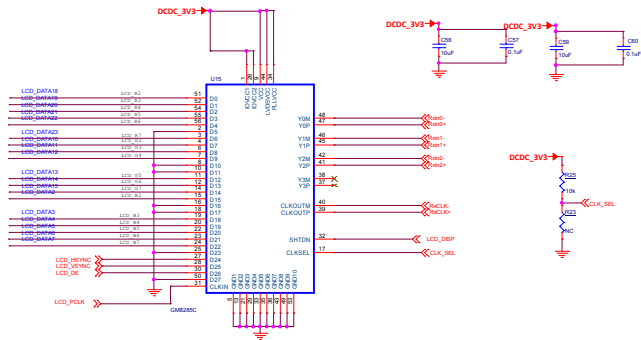

4.3 LCD RGB Interface

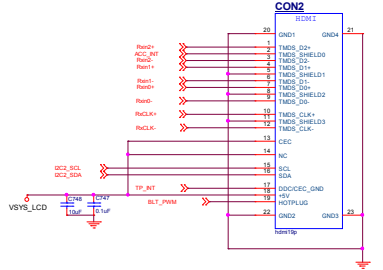
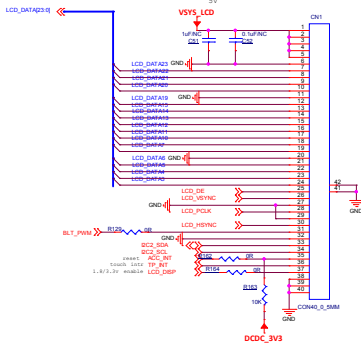

USB HOST/OTG

- USB_OTG1_DN <-> USB_OTG1_DN
- USB_OTG1_DP <-> USB_OTG1_DP
- USB_OTG2_DN <-> USB_OTG2_DN
- USB_OTG2_DP <-> USB_OTG2_DP

- USB_OTG1_PWR <-> USB_OTG1_PWR
- USB_OTG2_PWR <-> USB_OTG2_PWR
- USB_OTG1_ID <-> USB_OTG1_ID
- USB_OTG1_OC <-> USB_OTG1_OC
- USB_OTG2_OC <-> USB_OTG2_OC

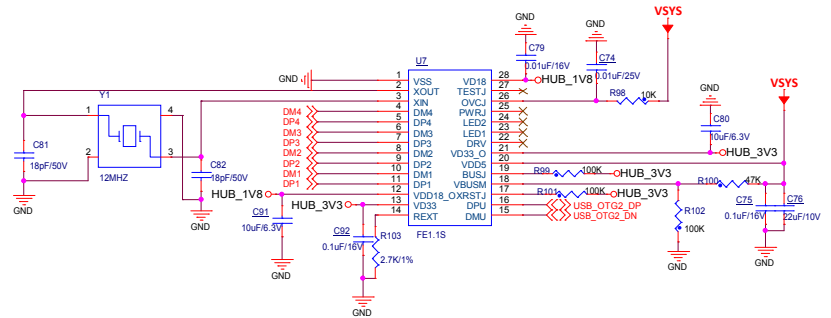
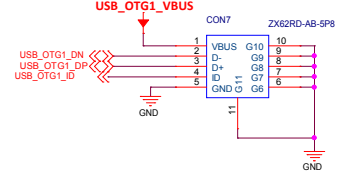
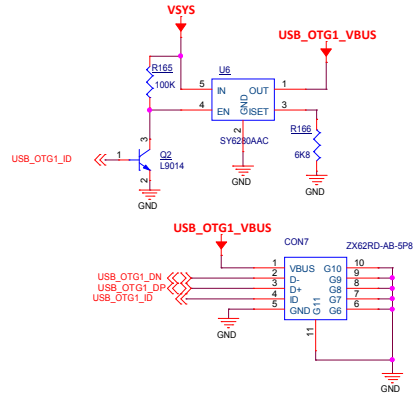

JTAG

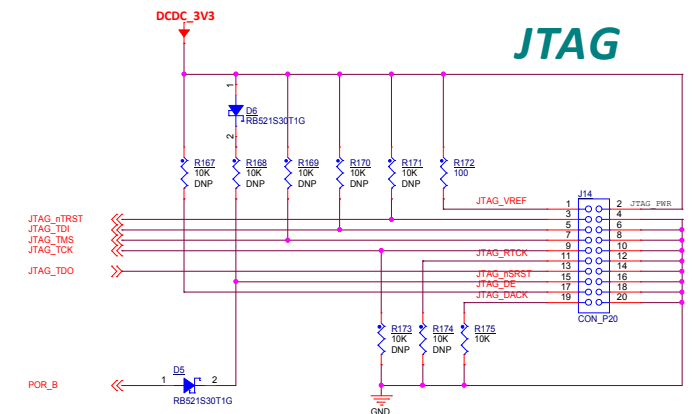

USB HOST

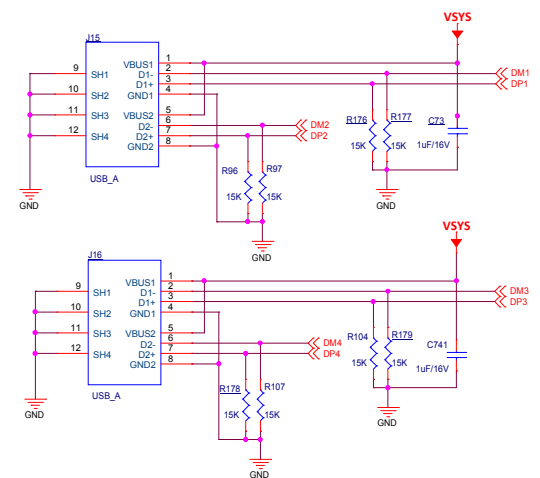

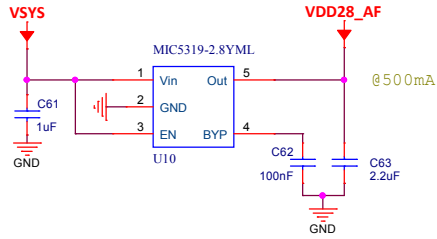

Camera / SIM

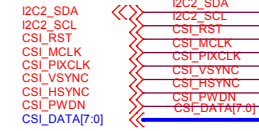

CAMERA Connector AVIN Connector

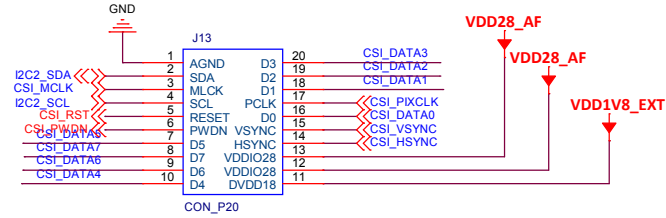
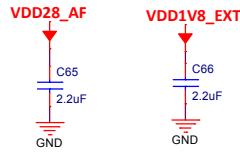

DC/DC 1.8V

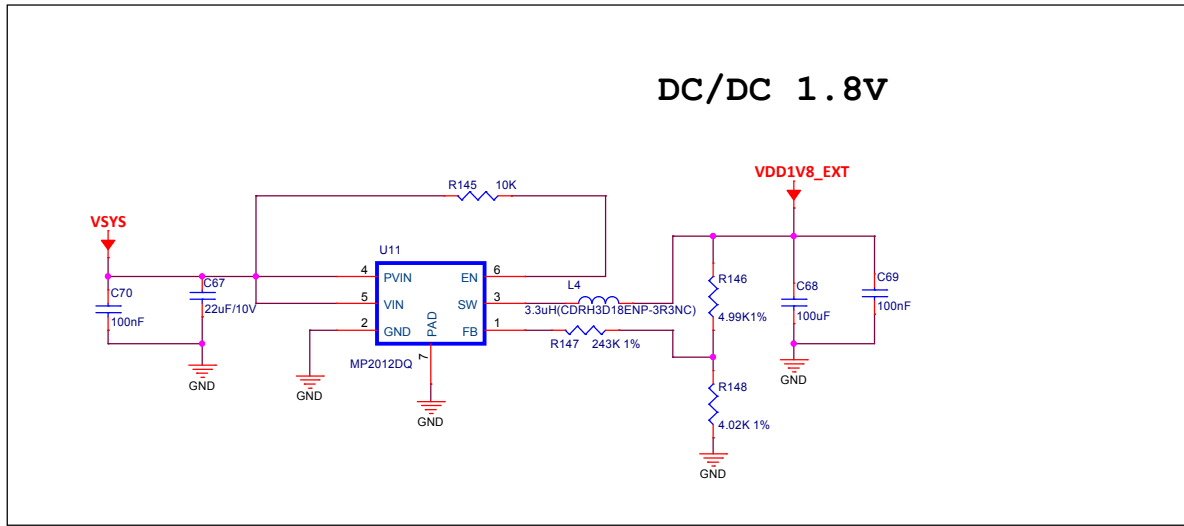

FUSE MAP

<Default: QSPI BOOT>
0/1 0/1 0/1 1 0 0 0 0

TYPE	BOOT_CFG1[7]	BOOT_CFG1[6]	BOOT_CFG1[5]	BOOT_CFG1[4]	BOOT_CFG1[3]	BOOT_CFG1[2]	BOOT_CFG1[1]	BOOT_CFG1[0]
QSPI	0	0	0	1	Reserved		DDRSMP: "000": Default "001-111"	
WEIM	0	0	0	0	Memory Type: 0 - NOR Flash 1 - OneNAND	Reserved	Reserved	Reserved
Serial-ROM	0	0	1	1	Reserved	Reserved	Reserved	Reserved
SD/eSD	0	1	0	Fast Boot: 0 - Regular 1 - Fast Boot	SD/SDHC Speed 00 - Normal/SDR12 01 - High/SDR25 10 - SDR50 11 - SDR104	SD Power Cycle Enable 0 - No power cycle 1 - Enabled via USDMC_RST pad (USDMC2 & 4 only)	SD Loopback Clock Source Sel for SDR50 and SDR104 only 0 - through SD pad 1 - direct	
MMC/eMMC	0	1	1	Fast Boot: 0 - Regular 1 - Fast Boot	SD/MMC Speed 0 - High 1 - Normal	Fast Boot Acknowledge Disable: 0 - Boot Ack Enabled 1 - Boot Ack Disabled	SD Power Cycle Enable 0 - No power cycle 1 - Enabled via USDMC_RST pad (USDMC2 & 4 only)	SD Loopback Clock Source Sel for SDR50 and SDR104 only 0 - through SD pad 1 - direct
NAND	1	BT_TOGGLEMODE	Pages in Block: 00 - 128 01 - 64 10 - 32 11 - 256	Nand Number Of Devices: 00 - 1 01 - 2 10 - 4 11 - Reserved	Nand Row Address Bytes: 00 - 3 01 - 2 10 - 4 11 - 5			

TYPE	BOOT_CFG2[7]	BOOT_CFG2[6]	BOOT_CFG2[5]	BOOT_CFG2[4]	BOOT_CFG2[3]	BOOT_CFG2[2]	BOOT_CFG2[1]	BOOT_CFG2[0]
QSPI	Reserved	HPMS: Half Speed Phase Select (on TBD) - 1 TBD	HSCLK: Half Speed Delay Select (on TBD) - 1 TBD	HPMS: Full Speed Phase Select (on TBD) - 1 TBD	HSCLK: Full Speed Delay Select (on TBD) - 1 TBD	Boot Frequencies (ARM/DMA) 0 - 500 / 400 MHz 1 - 250 / 200 MHz	Reserved	Reserved
WEIM	Mixing Scheme: 00 - A/D16 01 - A+D8 10 - A+D4 11 - Reserved	OneWord Page Size: 00 - 1KB 01 - 2KB 10 - 4KB 11 - Reserved		Reserved	Reserved	Boot Frequencies (ARM/DMA) 0 - 500 / 400 MHz 1 - 250 / 200 MHz	Reserved	Reserved
Serial-ROM	Reserved	Reserved	Reserved	Reserved	Reserved	Boot Frequencies (ARM/DMA) 0 - 500 / 400 MHz 1 - 250 / 200 MHz	Reserved	Reserved
SD/eSD	SD Calibrat i on & sep '00' - 1 TBD	Bus Width: 0 - 1-bit 1 - 4-bit TBD	Port Select: 00 - eSDHC1 01 - eSDHC2 10 - Reserved 11 - Reserved	Boot Frequencies (ARM/DMA) 0 - 500 / 400 MHz 1 - 250 / 200 MHz	SD2 VOLTAGE SELECTION 0 - 1.8V 1 - 1.9V	Reserved	Reserved	Reserved
MMC/eMMC	Bus Width: 000 - 4-bit 001 - 4-bit 010 - 4-bit 101 - 4-bit DDR (MMC 4.4) 110 - 8-bit DDR (MMC 4.4) Ehc - reserved	Port Select: 00 - eSDHC1 01 - eSDHC2 10 - Reserved 11 - Reserved	Boot Frequencies (ARM/DMA) 0 - 500 / 400 MHz 1 - 250 / 200 MHz	SD1 VOLTAGE SELECTION 0 - 1.8V 1 - 1.9V	Reserved	Reserved	Reserved	Reserved
NAND	Toggle Mode (33MHz Preamble Delay, Read Latency) '00' - 16 GPMCLK cycles '01' - 3 GPMCLK cycles '10' - 2 GPMCLK cycles '11' - 3 GPMCLK cycles '100' - 4 GPMCLK cycles '101' - 5 GPMCLK cycles '110' - 6 GPMCLK cycles '111' - 7 GPMCLK cycles	BOOT_SEARCH_COUNT: 00 - 2 01 - 3 10 - 4 11 - 8	Boot Frequencies (ARM/DMA) 0 - 500 / 400 MHz 1 - 250 / 200 MHz	Boot Time 0 - 2ms 1 - 2.5ms (LBA Next)	Reserved	Reserved	Reserved	Reserved

TYPE	BOOT_CFG4[7]	BOOT_CFG4[6]	BOOT_CFG4[5]	BOOT_CFG4[4]	BOOT_CFG4[3]	BOOT_CFG4[2]	BOOT_CFG4[1]	BOOT_CFG4[0]
0x450	Infi nit-Loop (Debug USE only) 0 - Disable 1 - Enable	EEPROM Recovery Enable '0' - Disabled '1' - Enabled	CS select (SPI only): 00 - CS#0 (default) 01 - CS#1 10 - CS#2 11 - CS#3	SPI Addressing: 0 - 2-bytes (16-bit) 1 - 3-bytes (24-bit)	Reserved	Reserved	Reserved	Reserved
0x460	L2_HW_INVALIDATE_DISABLE	Reserved	FORCE_COLD_BOOT (Ref) ect ed n SB M3	BT_FUSE_SEL	DIR_BT_DIS	Reserved	SEC_CONFIG[1]	Reserved
0x460	Reserved (DDR3 confi g opti on)							
0x460	JTAG_SMODE[1:0]	WDOG_ENABLE '0' - Disabled '1' - Enabled	SJC_DISABLE	Reserved	Reserved	Reserved	Reserved	Reserved
0x460	Reserved	Reserved	Reserved	TZASC_ENABLE	JTAG_HEO	KTE	Reserved	DLL_ENABLE 0 - Disable DLL for SD/eMMC 1 - Enable DLL for SD/eMMC
0x470	DLL Override: 0 - DLL Stave Mode for SD/eMMC 1 - DLL Override Mode for SD/eMMC	Reserved	SD2 VOLTAGE SELECTION 0 - 3.3V 1 - 1.8V	Reserved	Disable SDRAM Manufacture mode 0 - Enable 1 - Disable	L1 I-Cache DISABLE	BT_MMU_DISABLE	Override Pad Settings (using PAD_SETTINGS value)
0x470	Reserved for unexpected requirements	MMC 4.4 - RESET TO PRE-IDLE STATE	Override HYS bit for SD/MMC pads	USDMC_PAD_PULL_DOWN 0 - no sct i on 1 - pull-down	ENABLE_EMMC_22K_PULLUP 0 - 47K pullup 1 - 22K pullup	ADD_DS_SET_GPR1_16 0 - Set 1 - Don't set	USDMC_IOMUX_SION_BIT_ENA 0 - Disable 1 - Enable	ALBSDMC_IOMUX_SRE_Enable 0 - Disable 1 - Enable
0x470	USDMC_CMD_DE_PRE_EN (SD/MMC debug)	LPB_BOOT (Core / DDR - Bus) '00' - LPB Disable '01' - 1 GPO (def freq) '10' - Div by 2 '11' - Div by 4	BT_LPB_POLARITY (GPIO polarity)	POWER_MNG_CFG (LDO's DCDC's) (Reserved - NOT USED)				
0x470	Override NAND Pad Set 1 mg (using PAD_SETTINGS value)	MMC_DLL_DLY[6:0] Delay target for SD/eMMC DLL, it is applied to slave mode target delay or override mode target delay depends on DLL Override fuse bit value.						

NAND MT29F32G08CBACA

1 page = (4K + 224 bytes)
1 block = (4K + 224) bytes x 256 pages
= (1024K + 56K) bytes
1 plane = (1024K + 56K) bytes x 2048 blocks
= 17.280Mb
1 LUN = 17.280Mb x 2 planes
= 34.560Mb

Boot Configuratio

BMODE[1:0]	BOOT TYPE
00	Boot From Fuses
01	Serial Downloader
10	Internal Boot (Development)
11	Reserved

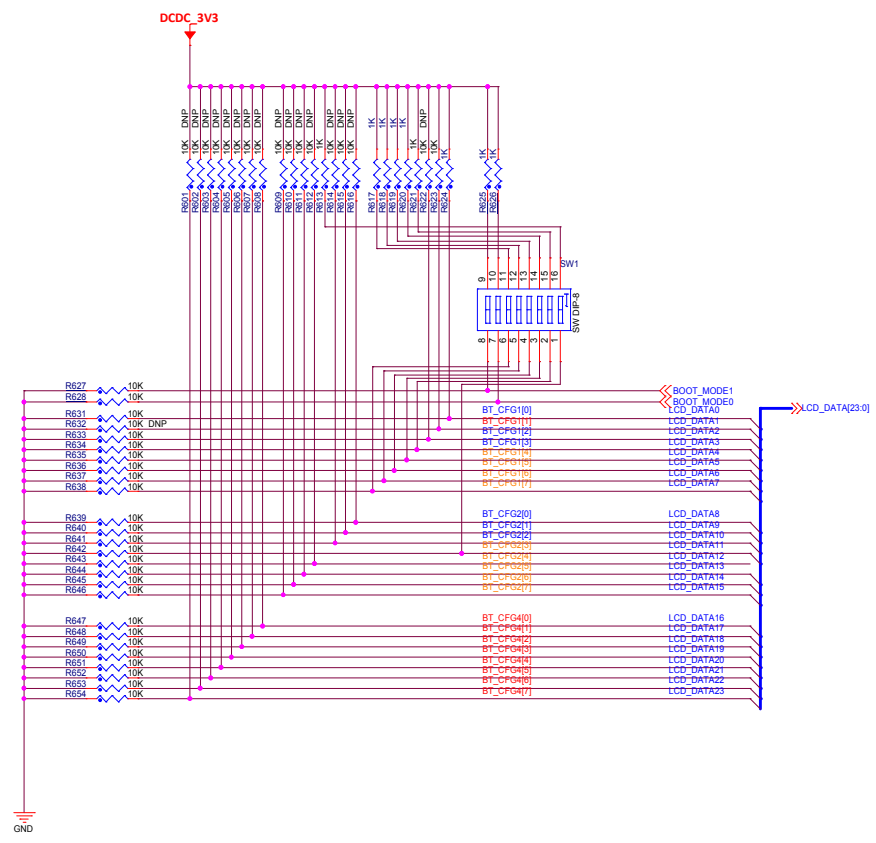

freescale Microcontroller Solutions Group
6501 William Cannon Drive West
Austin, TX 78735-8588

This document contains information proprietary to Freescale Semiconductor and shall not be used for engineering design, procurement or manufacture in whole or in part without the express written permission of Freescale Semiconductor.

ICAP Classification: FCP: FIUO: X PUBI:

Designer: DESIGNER
Drawing Title: MCIMX6UL-CM
Drawn by: DRAWN_BY
Page Title: BOOT CFG
Approved: APPROVER
Size C
Document Number: SCH-28617 PDF: SPF-28617
Rev C1
Date: Wednesday, November 20, 2019
Sheet 9 of 13

SODIMM 146

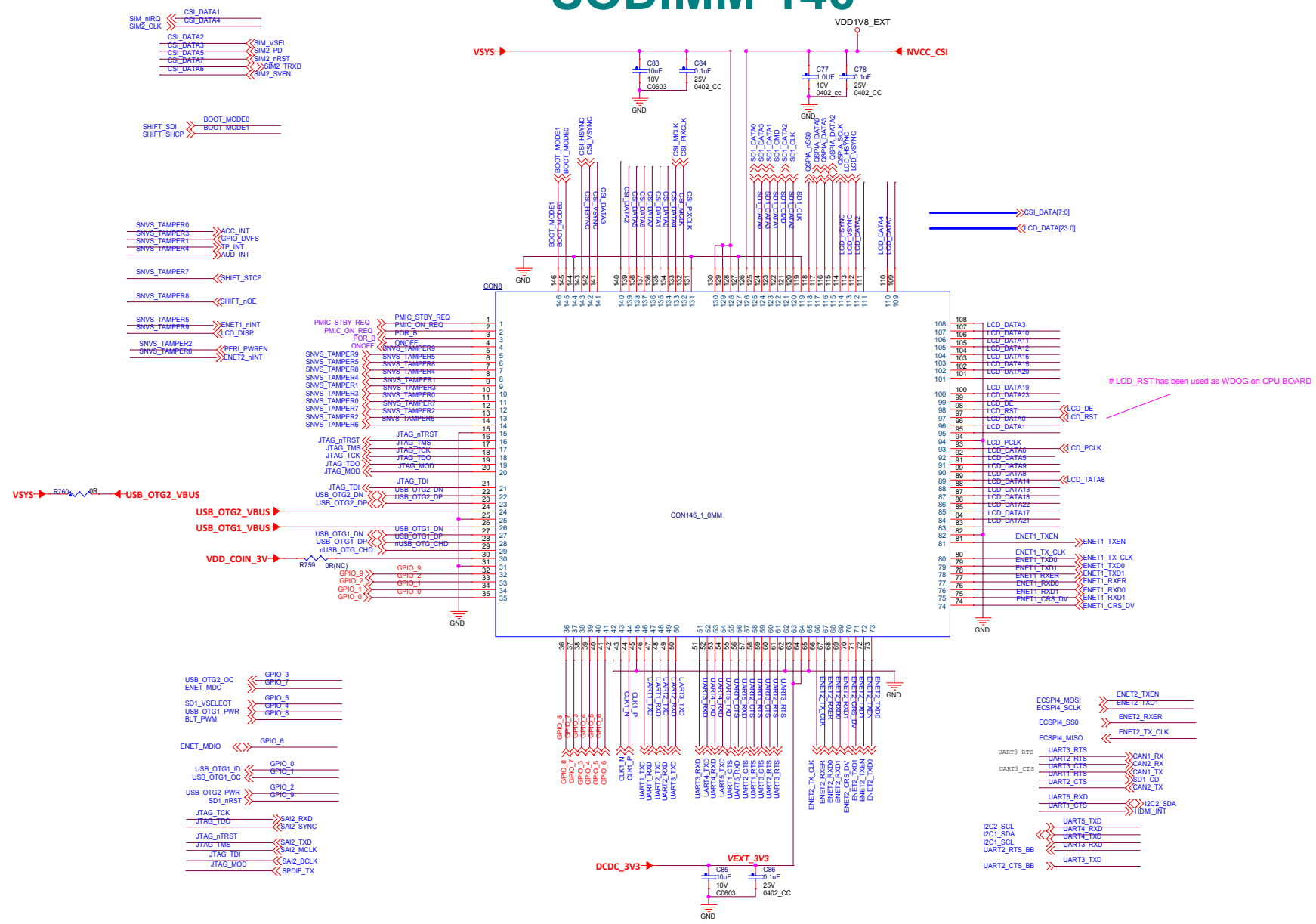

Title		
BOARD CONNECTOR		
Size	Document Number	Rev
C		V1.0
Date:	Wednesday, June 27, 2018	Sheet 11 of 11